

FREEWAY *transactive* Xtra



PRISM MEDICAL UK

Superior solutions. Exceptional service.

INSTALLATION SOLUTIONS

...AND A TRACKING SYSTEM FOR EVERY SITUATION

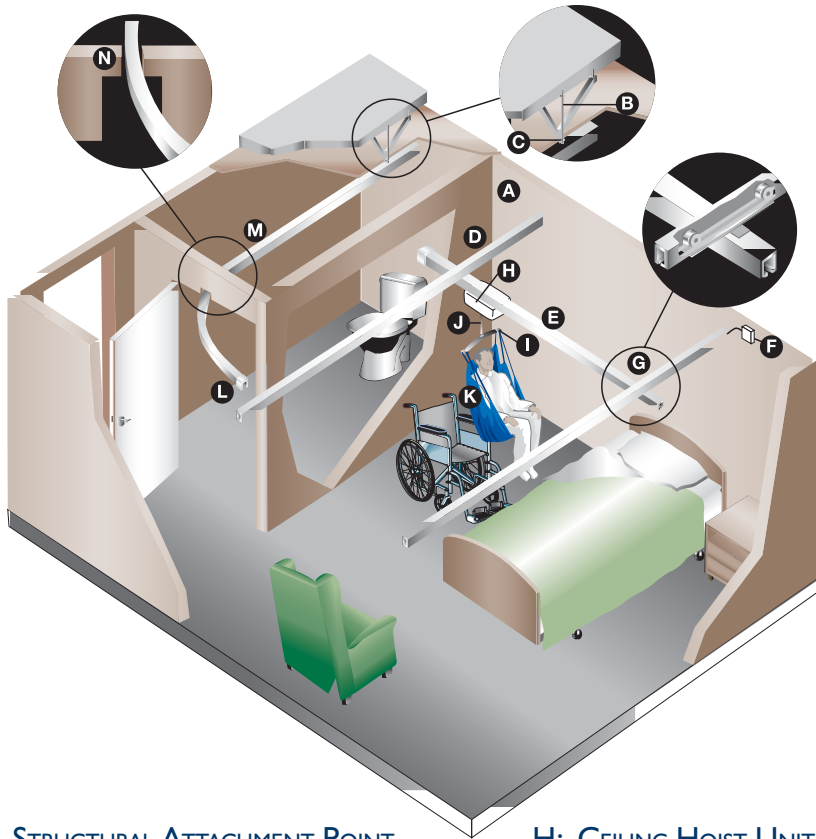

- A: STRUCTURAL ATTACHMENT POINT
- B: THREADED ROD
- C: TRACK BRACKET
- D: TRACK
- E: TRAVERSING BEAM ('H' SYSTEM)
- F: CHARGING DOCK
- G: 'H' SYSTEM

- H: CEILING HOIST UNIT
- I: CARRY BAR
- J: LIFTING TAPE
- K: SLING
- L: TRANSITION GATE
- M: CURVED TRACK
- N: MODIFIED DOOR HEADER

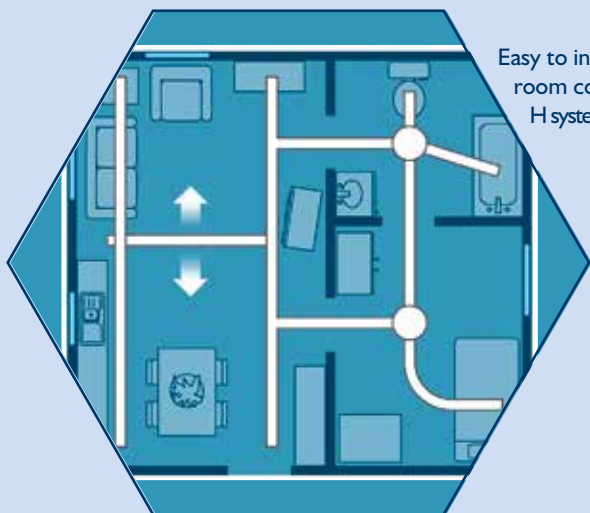
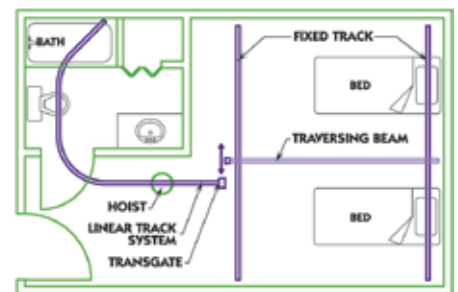
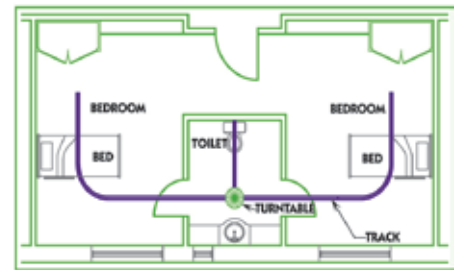
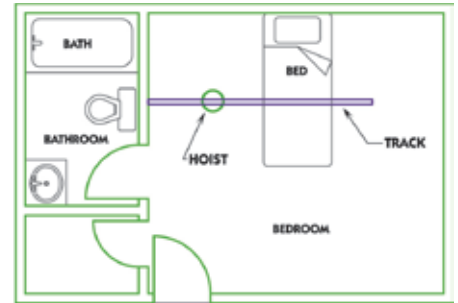

Easy to install whole room cover H systems



TRANSACTIVE XTRA

THE COMPACT HOIST WITH EXTRA FEATURES...

The all new Transactive Xtra, a product of world class design and state of the art features providing safe, reliable and effective hoisting for carers and users alike. Together with the extensive range of track configurations, the Transactive Xtra can provide the perfect solution to your hoisting requirements.

- **Slimline and with great lifting capacity**
- **Low profile hoist unit is unobtrusive and provides greater lifting height**
- **All lifting and traversing operations have soft start/stop to ensure smooth transfers for the user**
- **A host of safety features**
- **Smooth running tape with large lifting range**
- **State of the art display with lift counter**

Slimline low profile padded carry bar has six sling loop attachment points as standard (four hook as option) different width carry bars available

Ergonomically designed handset with hold to run clearly marked buttons and directional arrows requires minimum pressure to operate. Pneumatically controlled, it is therefore safe for use in wet conditions.



Fire retardant cover completely encapsulates hoist

Neat in track transformer IP 67 rated

Coloured Direction indicators on hoist unit match hand control to ensure correct operation first time

Emergency stop and electric emergency window

**130kgs, 160kgs, 200kgs, 270kgs
MODELS AVAILABLE**

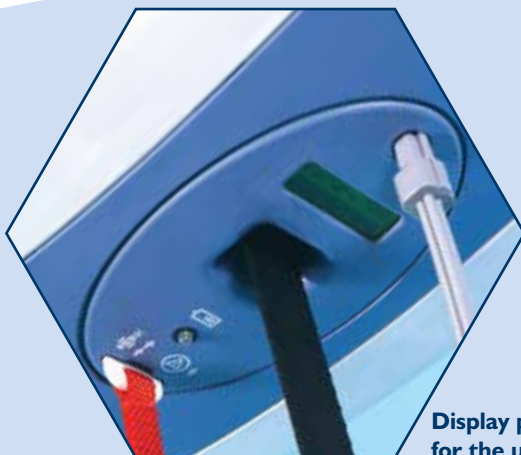

Display provides essential information for the user carer and engineer.

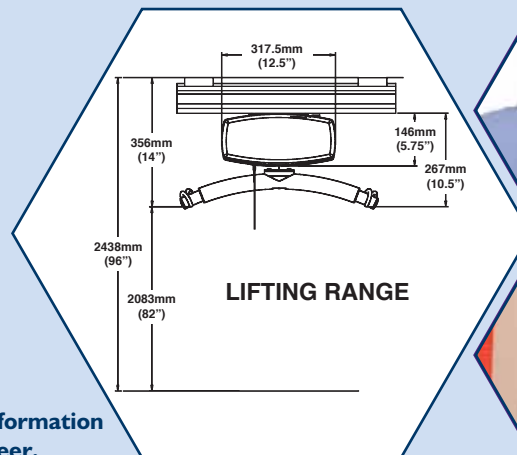

- Lift counter
- Displays operation being carried out (UP/ DOWN etc)
- Charge level of battery • Low battery indicator (visual and audial)
- On charge indicator • Return to charge (Option)
- Diagnostic feature for transactive engineer to aid maintenance and repair

Manual window and raising.

This feature is unique to Freeway hoists and allows the hoist to continue to be used until the engineer arrives. This provides peace of mind and security to carer and user.

TRACK AND ACCESSORIES

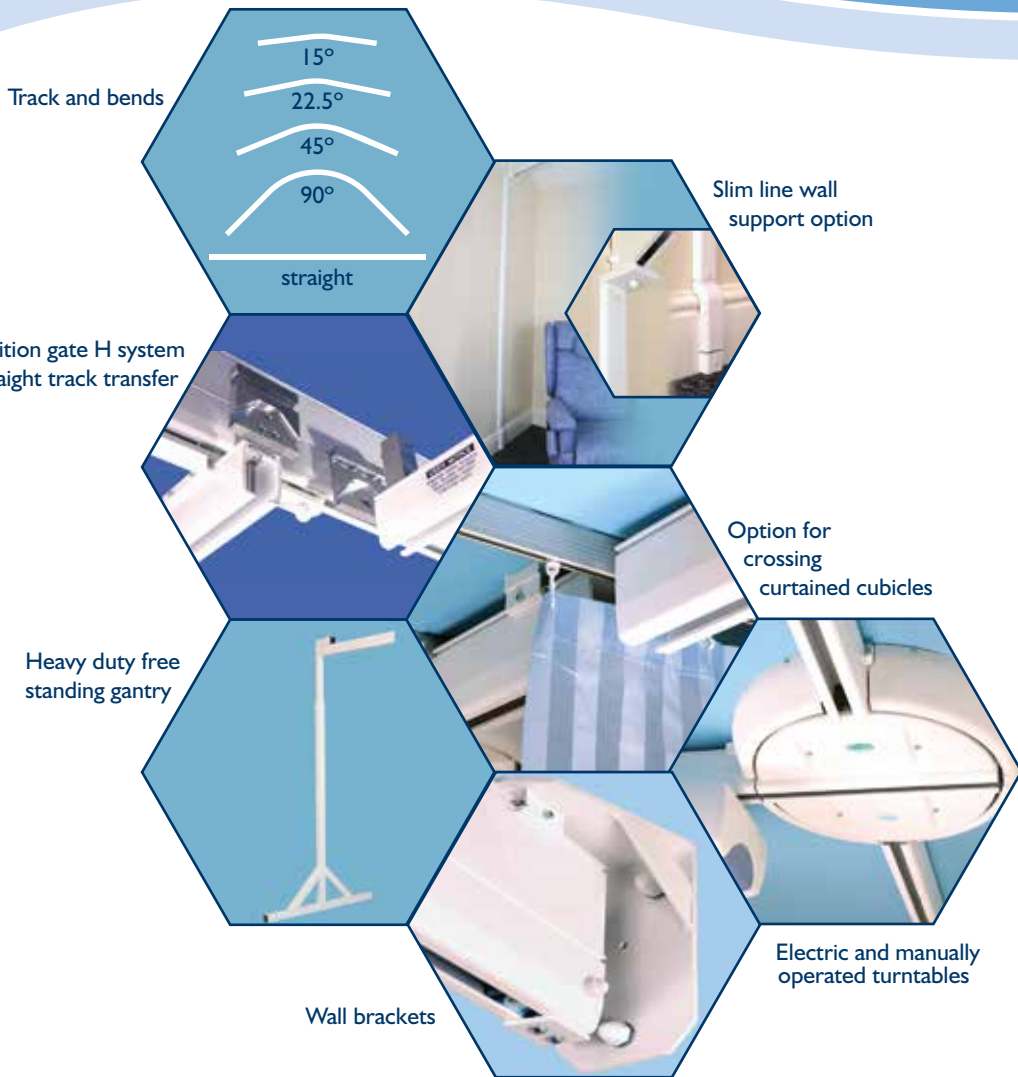

SPECIFICATION

MAX SAFE WORKING LOAD: 130KGS, 160KGS, 200KGS, 270KGS.

APPROX NUMBER OF LIFTS BEFORE RECHARGE: WITH 85 KG LOAD APPROX 65

CHARGING TIME: 8HOURS MAX

UNIT WEIGHT INC BATTERIES:
MANUAL: 9.7KGS
DRIVE: 10.4KGS

LIFTING SPEED:
AVERAGE UP SPEED UNLOADED = 40MM/S

AVERAGE UP SPEED WITH 200KG = 28MM/S
AVERAGE UP SPEED WITH 150KG = 33MM/S
AVERAGE UP SPEED WITH 100KG = 38MM/S

THESE FIGURES ARE BASED ON 100% FULL BATTERY CHARGE.

BATTERIES: 2 X 12V 5AMP
BATTERY PROTECTION: SLEEP MODE
VOLTAGE 24VDC

TRANSFORMER : 1P 65 RATED
28.8V AC OUTPUT
100-240V AC INPUT
50/60Hz

The Freeway TransactiveXtra is manufactured in the UK to meet and exceed all relevant design, safety and quality standards.

✓ BS EN ISO 10535:2006 Compliant
'Hoists for the transfer of disabled persons – Requirements and test methods'



FULL 2 YEAR WARRANTY (excludes batteries)

Prism Medical Registered Office

Tel: +44 (0) 1924 840 100 Email: info@prismmedical.co.uk
Unit 4, Jubilee Business Park, Jubilee Way, Grange Moor, Wakefield, West Yorkshire, WF4 4TD

Prism Medical Manufacturing Centre

Tel: +44 (0) 1745 342 212 Email: info@prismmedical.co.uk
Unit 1, Tir Llwyd Industrial Estate, St Asaph Avenue, Kinmel Bay, Rhyl, Conwy LL18 5JZ

